

Digital Storytelling

Michelle Shapiro, The TOPS Program

Shelia Jackson, The TOPS Program

Peggy Koniz-Booher, SPRING

Kristiana Beall, SPRNG

TOPS FSN Networks Asia Regional Knowledge Sharing Meeting
March 4, 2015

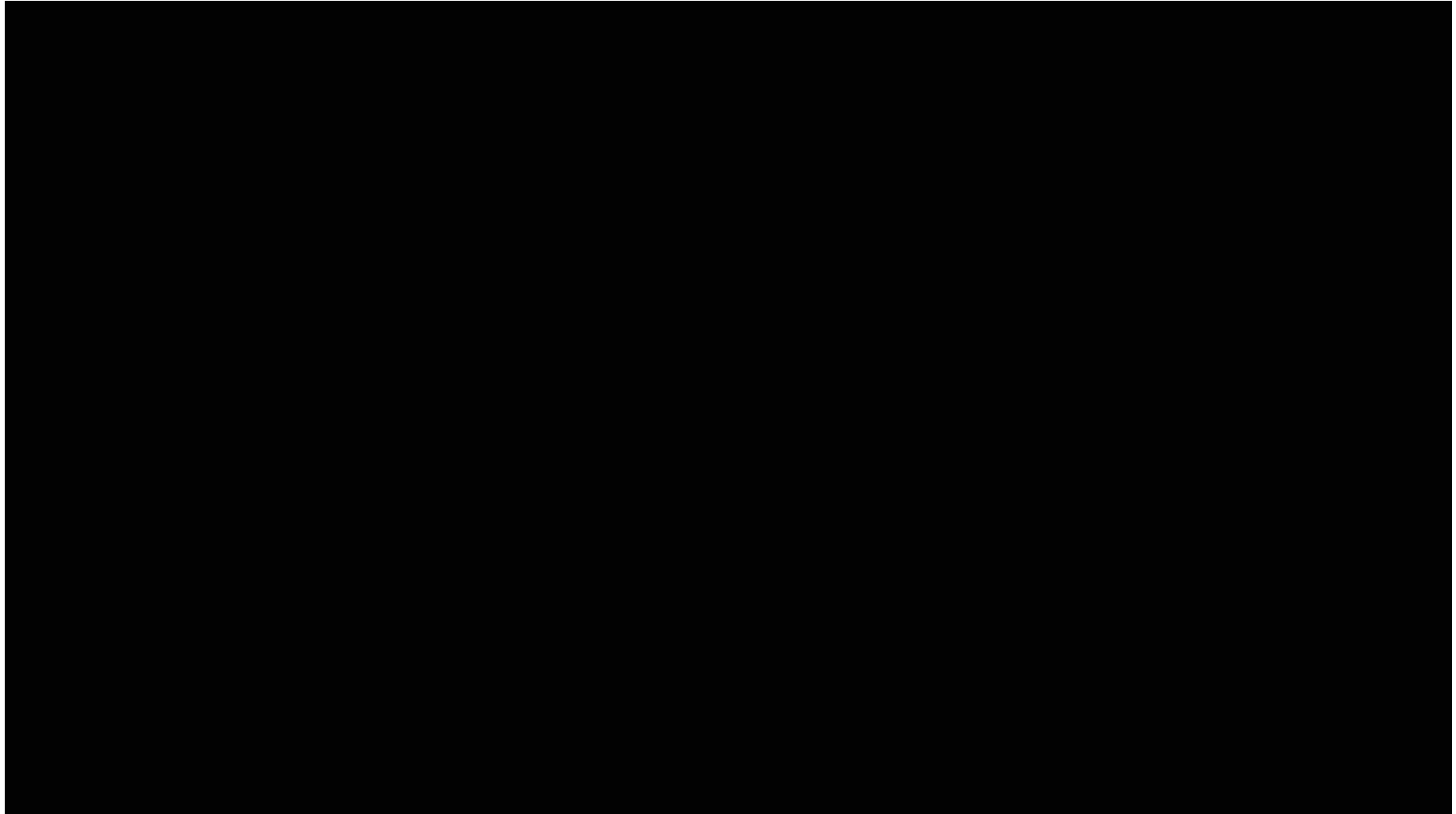

Why use a video to communicate behavior change and education?

- Make complex issues easier to understand
- Context along with facts
- Emotional connections
- Reach a wider audience
- Share and capture knowledge

Planning a video: Pre-production

- Objective
- Assign roles
- End product
- Script
- Storyboarding
- Location and actors



Planning a video: Production and Post-production

- Shoot
- Edit
- Distribute

A Storyboard Is...

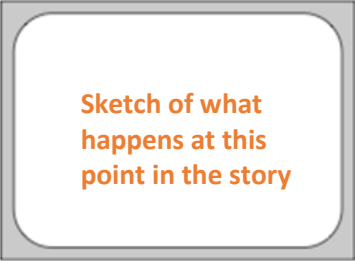

A written and graphical representation of all elements included in the video.

A Storyboard Includes...

<u>PAGE:</u>	<u>DATE:</u>	<u>PROJECT NAME:</u>	<u>AUTHOR:</u>
 <p>Sketch of what happens at this point in the story</p>	FRAME DESCRIPTION		MEDIA LIST AND DESCRIPTION
	<ul style="list-style-type: none"> • What will appear on the screen (picture, clip, graphic) • What listeners will hear (music, narrative, sounds) 		<ul style="list-style-type: none"> • Music, songs, sounds • Pictures, graphics, diagrams • Video clip • Text, titles
<u>NARRATION:</u>			
Write out or describe the narrative – who is talking and what they are saying.			
			
	<u>NARRATION:</u>		

Source: www.jasonohler.com

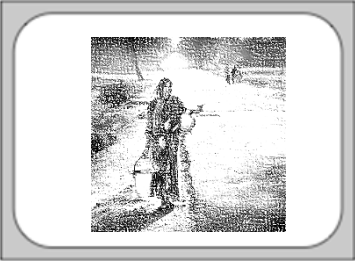
Storyboard Example:

<u>PAGE:</u>	<u>DATE:</u>	<u>PROJECT NAME:</u>	<u>AUTHOR:</u>
		FRAME DESCRIPTION	MEDIA LIST AND DESCRIPTION
		<ul style="list-style-type: none"> • Basanti walks toward the camera, holding a container • Background music plays • Basanti speaks 	<ul style="list-style-type: none"> • Background music • Video clip of Basanti walking • Audio clip of Basanti talking • Subtitles
<p><u>NARRATION:</u></p> <p>BASANTI: My name is Basanti Majhi.</p>			
		<ul style="list-style-type: none"> • Basanti puts her child on her lap • Background music plays • Basanti speaks 	<ul style="list-style-type: none"> • Background music • Video clip of Basanti walking • Audio clip of Basanti talking • Subtitles
		<p><u>NARRATION:</u></p> <p>BASANTI: I do agricultural work.</p>	

Source: www.jasonohler.com

Storyboarding Considerations

- What are the needs of the beneficiaries?
- Are the characters/actors relatable?
- Is the situation relatable?
- Are the solutions realistic?
- Are you aware of important cultural norms?

Now it's your turn!

In small groups...

1. Decide on a topic (1 minute)
 - Handwashing
 - Storage of food commodities
 - HIV testing at a health clinic
2. Assign Roles (1 minute)
 - Director
 - Writer
 - Videographer
3. Brainstorm & Outline (6 minutes)
4. Storyboard (10 minutes)

Video Camera Tutorial

Front & Left

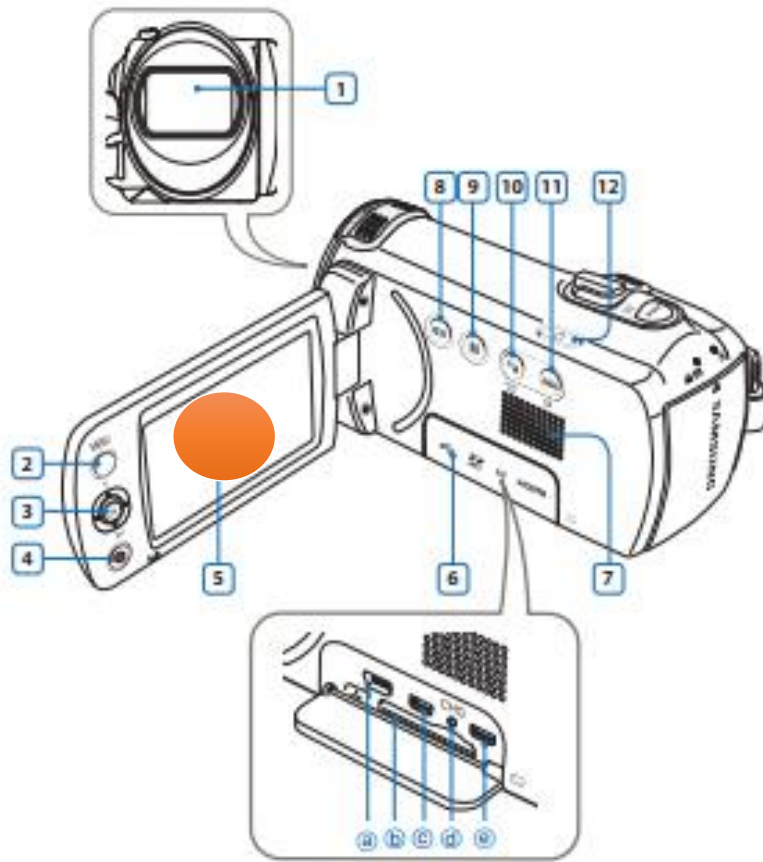

- 1** Lens

- 2** MENU button

- 3** Control (Up/Down/Left/Right/Ok) button / Zoom (T/W) button

- 4** Recording start/stop button

- 5** LCD screen

- 6** Memory card/Jack cover
 - a USB jack (←→)
 - b Memory card slot (→)
 - c AV jack (AV)
 - d CHG (charging) indicator
 - e HDMI jack (HDMI)

- 7** Internal speaker

- 8** Display (☺) button

- 9** Recording pause/resume (⏸) button

- 10** Back light (☺) button / SMART BGM button

- 11** SMART AUTO (SMART AUTO) button / Share (📷) button

- 12** Power (⏻) button

Video Camera Tutorial

Front & Left

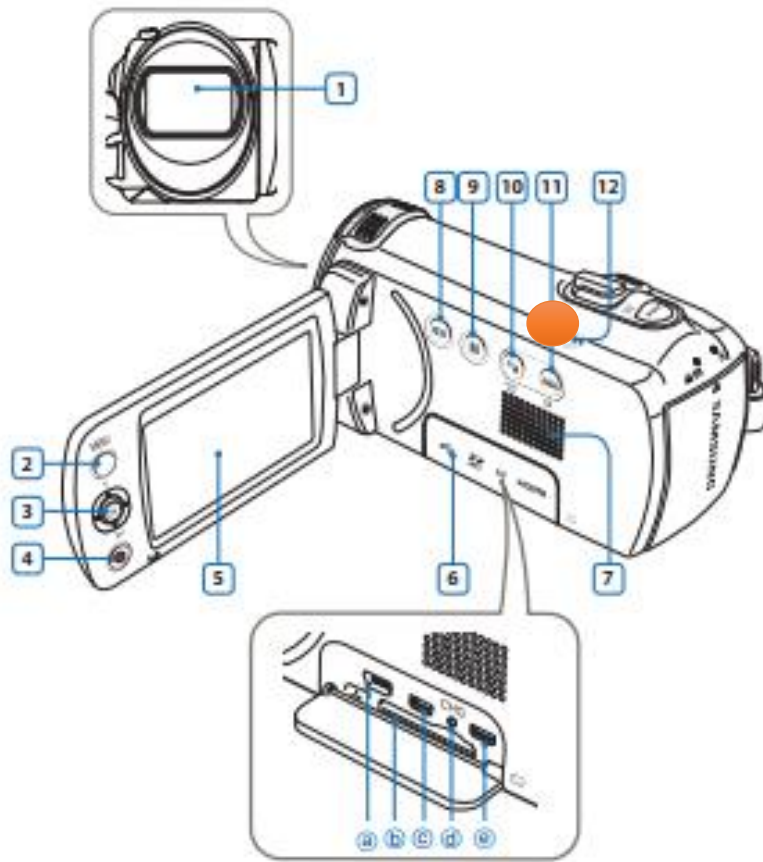

- 1** Lens

- 2** MENU button

- 3** Control (Up/Down/Left/Right/Ok) button / Zoom (T/W) button

- 4** Recording start/stop button

- 5** LCD screen

- 6** Memory card/Jack cover
 - a USB jack (←→)
 - b Memory card slot (SD)
 - c AV jack (AV)
 - d CHG (charging) indicator
 - e HDMI jack (HDMI)

- 7** Internal speaker

- 8** Display (☺) button

- 9** Recording pause/resume (⏸) button

- 10** Back light (☾) button / SMART BGM button

- 11** SMART AUTO (SMART AUTO) button / Share (📷) button

- 12** Power (⏻) button

Video Camera Tutorial

Right/Top & Bottom

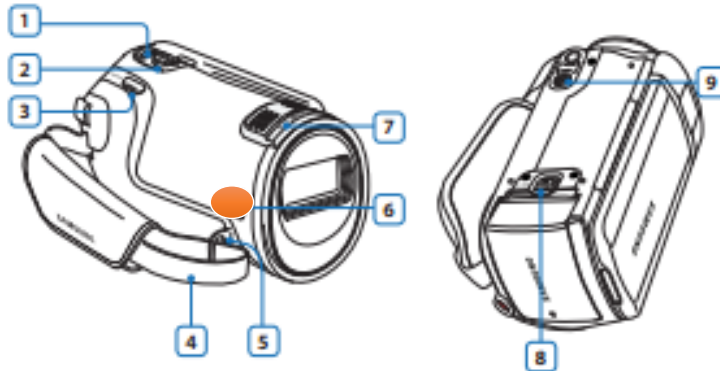

- | | |
|---|--------------------------------------|
| 1 | MODE button |
| 2 | Zoom lever (T/W) |
| 3 | PHOTO / My Clip button |
| 4 | Strap |
| 5 | Strap hook |
| 6 | Lens cover open (☺)/close (☹) switch |
| 7 | Internal microphone |
| 8 | Battery release switch (BATT.) |
| 9 | Tripod receptacle |

Video Camera Tutorial

Front & Left

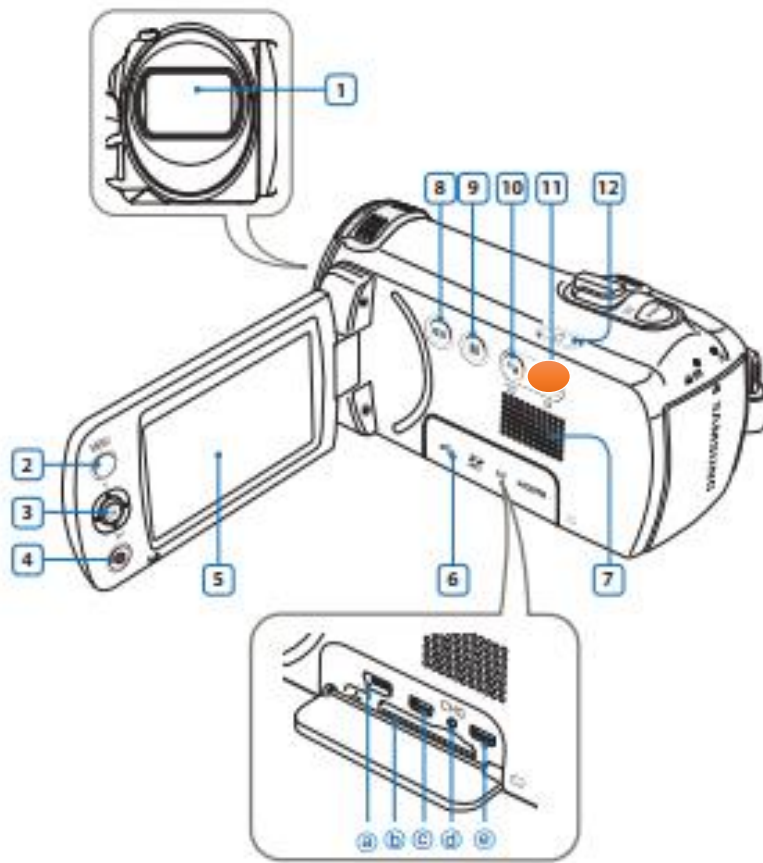



- | | |
|----|--|
| 1 | Lens |
| 2 | MENU button |
| 3 | Control (Up/Down/Left/Right/Ok) button / Zoom (T/W) button |
| 4 | Recording start/stop button |
| 5 | LCD screen |
| 6 | Memory card/Jack cover
a USB jack (←→)
b Memory card slot (→)
c AV jack (AV)
d CHG (charging) indicator
e HDMI jack (←HDMI) |
| 7 | Internal speaker |
| 8 | Display (☺) button |
| 9 | Recording pause/resume (⏸) button |
| 10 | Back light (☾) button / SMART BGM button |
| 11 | SMART AUTO (SMART AUTO) button / Share (📷) button |
| 12 | Power (⏻) button |

Video Camera Tutorial

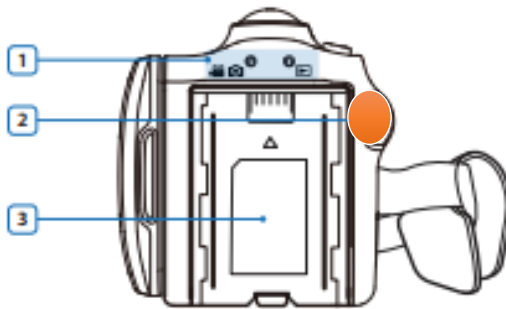
Rear



1 Mode indicator
  : Recording mode (Video/Photo)
 : Playback mode

2 Recording start/stop button

3 Battery slot

 Be careful not to cover the internal microphone and lens during recording.

Video Camera Tutorial

Front & Left

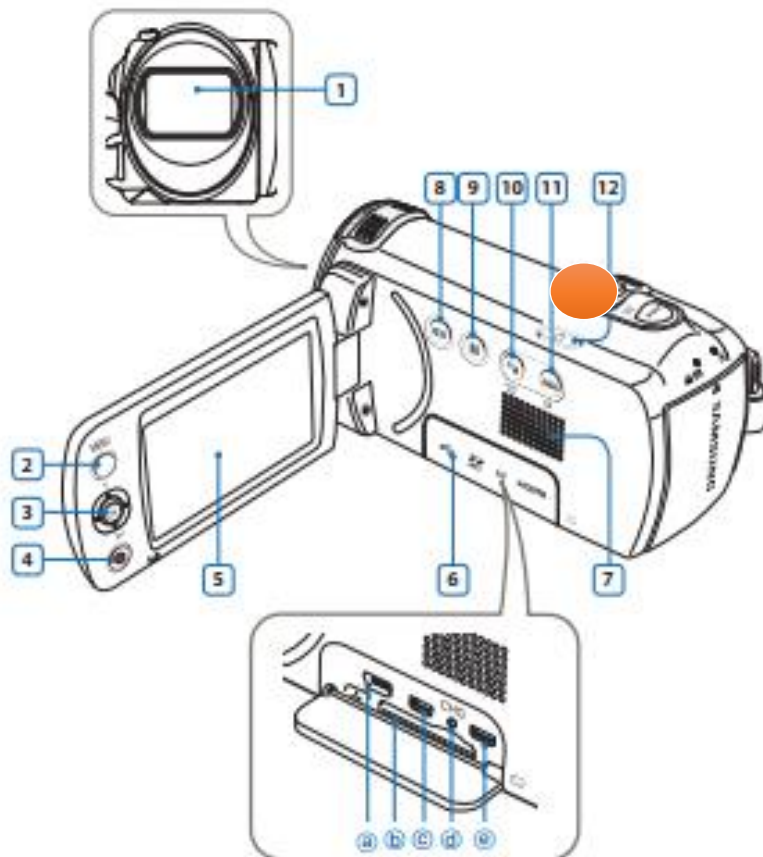

- 1 Lens
- 2 MENU button
- 3 Control (Up/Down/Left/Right/Ok) button / Zoom (T/W) button
- 4 Recording start/stop button
- 5 LCD screen
- 6 Memory card/Jack cover
 - a USB jack (←→)
 - b Memory card slot (→)
 - c AV jack (AV)
 - d CHG (charging) indicator
 - e HDMI jack (HDMI)
- 7 Internal speaker
- 8 Display (☺) button
- 9 Recording pause/resume (⏸) button
- 10 Back light (☾) button / SMART BGM button
- 11 SMART AUTO (SMART AUTO) button / Share (📷) button
- 12 Power (⏻) button

Video Camera Tutorial

Front & Left

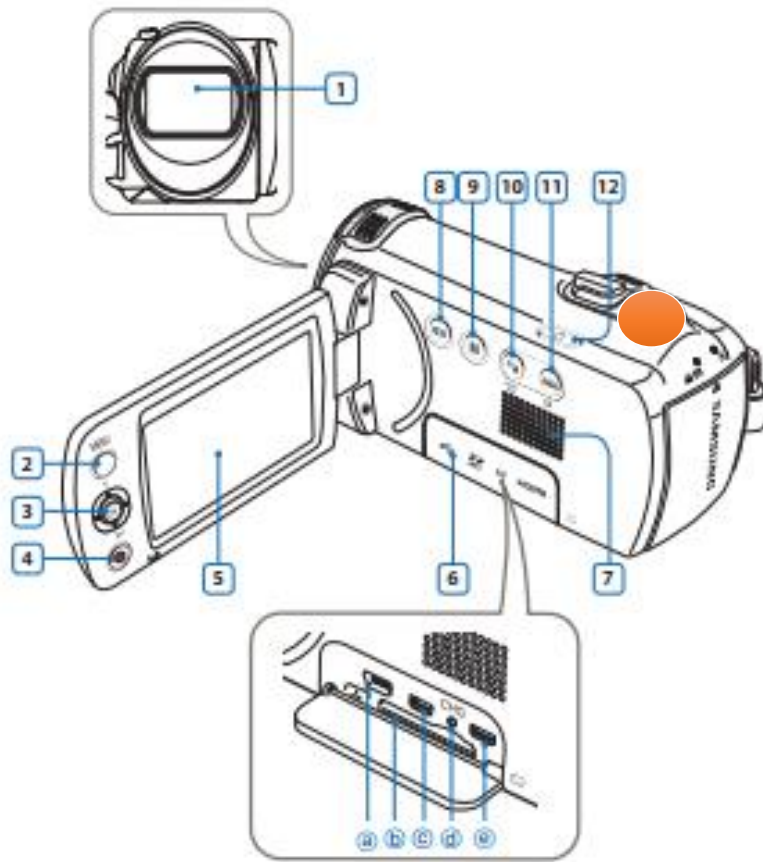

- 1** Lens

- 2** MENU button

- 3** Control (Up/Down/Left/Right/Ok) button / Zoom (T/W) button

- 4** Recording start/stop button

- 5** LCD screen

- 6** Memory card/Jack cover
 - a USB jack (←→)
 - b Memory card slot (→)
 - c AV jack (AV)
 - d CHG (charging) indicator
 - e HDMI jack (HDMI)

- 7** Internal speaker

- 8** Display (☺) button

- 9** Recording pause/resume (⏸) button

- 10** Back light (☺) button / SMART BGM button

- 11** SMART AUTO (SMART AUTO) button / Share (📷) button

- 12** Power (⏻) button

Video Camera Tutorial

Front & Left

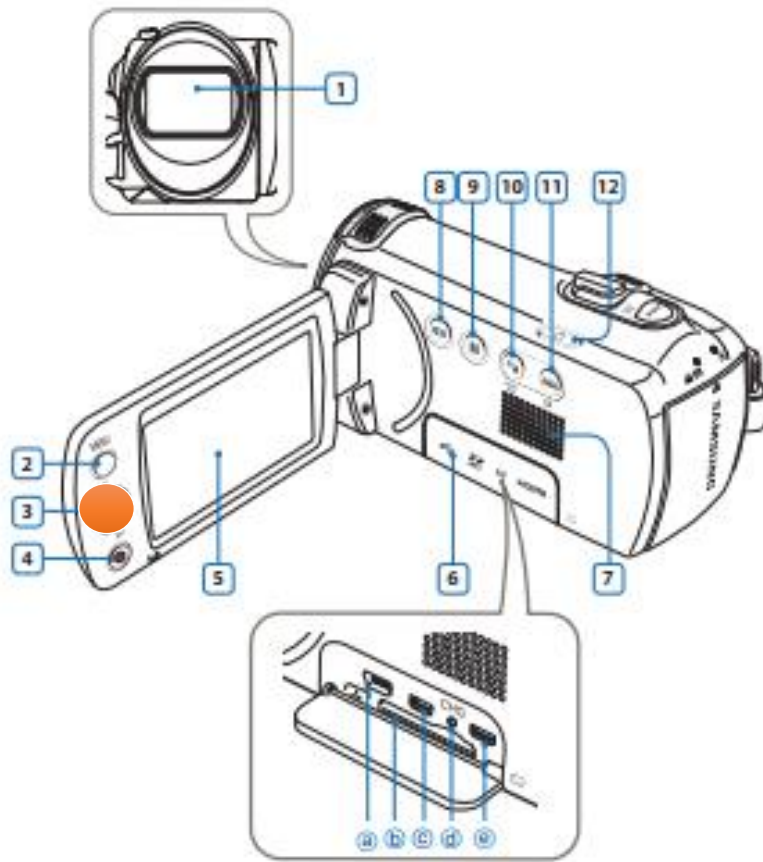

- | | |
|----|---|
| 1 | Lens |
| 2 | MENU button |
| 3 | Control (Up/Down/Left/Right/Ok) button / Zoom (T/W) button |
| 4 | Recording start/stop button |
| 5 | LCD screen |
| 6 | Memory card/Jack cover
a USB jack (←→)
b Memory card slot (→)
c AV jack (AV)
d CHG (charging) indicator
e HDMI jack (HDMI) |
| 7 | Internal speaker |
| 8 | Display (☺) button |
| 9 | Recording pause/resume (⏸) button |
| 10 | Back light (☺) button / SMART BGM button |
| 11 | SMART AUTO (SMART AUTO) button / Share (📷) button |
| 12 | Power (⏻) button |

Filming Considerations

- Lighting
- Sound
- Stability
- Variation

Editing

Free or Low-cost Video Editing Programs:

- Windows Movie Maker
- Apple iMovie
- Lightworks

