



**USAID**  
FROM THE AMERICAN PEOPLE

# **Saving Lives and Killing Pests: Fumigation and Protection of Warehoused Food Aid Commodities**

**Erika Clesceri, DCHA Bureau Environmental Officer &  
Emily Kunen, DCHA Environmental Advisor, USAID Washington;  
Arianne Neigh, Acting REA, USAID Southern Africa**

***TOPS/FSN Knowledge Sharing Conference, July 10-11, 2014  
Washington DC***



**USAID**  
FROM THE AMERICAN PEOPLE

## **Agenda for this Session: (1.5 hr)**

- 1. Introductions (5 min)**
- 2. Key Findings of the PEA (15 min)**
- 3. Plenary Q & A (10 min)**
- 4. Break-Out Groups (20 min)**
- 5. Group Report Out (30 min)**
- 6. Synthesis (10 min)**



**USAID**  
FROM THE AMERICAN PEOPLE

# What is the problem?

## Commodity losses due to insect infestation

Loss of weight, nutritional value and synergistic interaction with **mycotoxins**



+

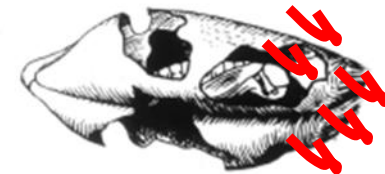
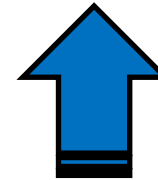
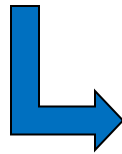

Food for Peace, Title II:

1-2 Million MT, ~\$1.7 B, ~50 Million people (FY10 & 11)



# Fumigants Basics

## Metal Phosphides (e.g., Tri-tox, Phostoxin, Quik-Fume)

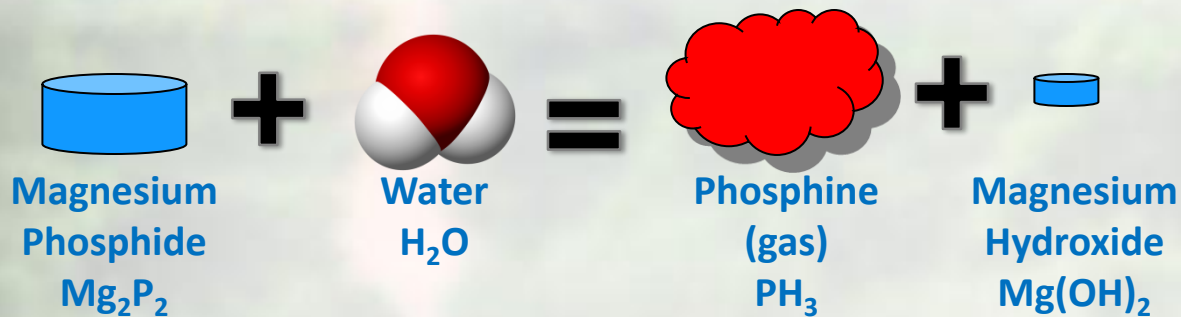

### Phosphine (gas):

- **Restricted Use Pesticide – High acute toxicity, inhalation**
- **Colorless, fish/garlic odor**
- **Highly explosive, corrosive**
- **Chemical warfare**



## Rehab symptoms match phosphine poisoning: Hospital

*Jul 10th, 2012 by admin.*

MUMBAI: Even as police officials and the Chougles deny that pest control was responsible for the deaths of Rameez and Rehab last week, the hospital that treated Rehab has verified that the victim and her family had offered this reason when they came for treatment.



## Contractor Arrested for Culpable Homicide

### What Happened?

- Two siblings, Rameez and Rehab Chougles vomited blood, died of inflammation of lung
- House was treated with phosphine by an unlicensed fumigator
- Entered a fumigated space and turned on the air conditioning without opening windows
- **Only < 1 gram used**

### What went wrong?

- No Markings indicating Fumigation
- Unlicensed Fumigator
- Obtained at a Local Chemical Store

# Safety & Efficacy Practices

## What Technology is Needed?

1. Appropriate PPE use and maintenance
2. Fumigation gas monitoring, efficacy and hazard
3. Gas impermeable tarps, sand snakes



Full-face respirator

Fumigation sheet covering the whole stack

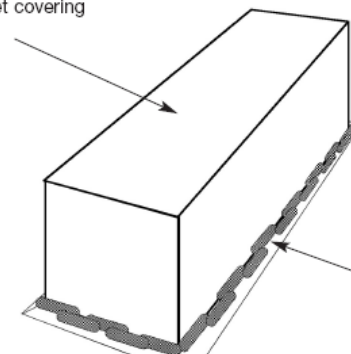

Sand snakes holding the sheet to the ground and overlapping by at least 0.3m



# Overview of Fumigation Programmatic Environmental Assessment

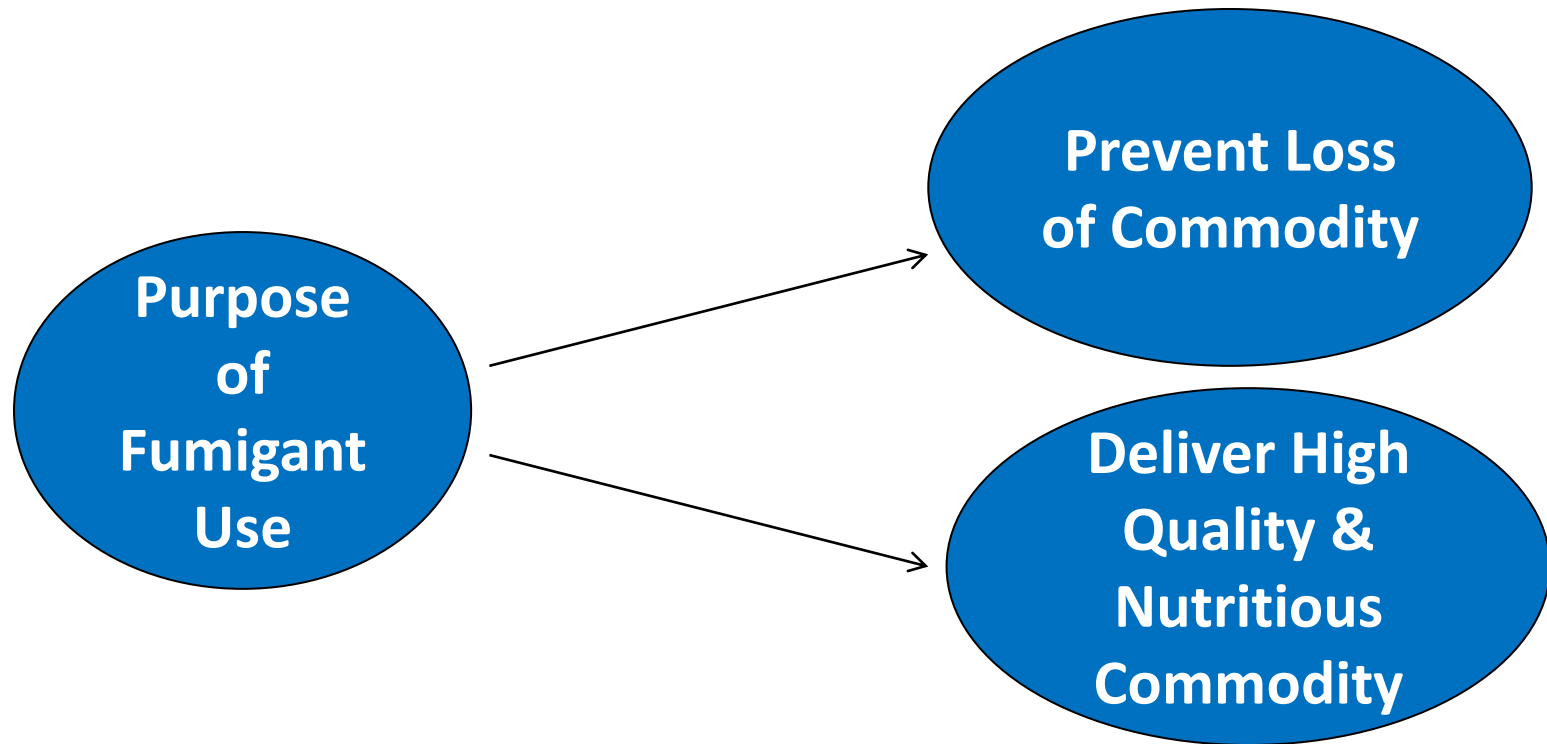

**Fumigants are an important tool,  
when used properly!**



# Environmental Compliance at USAID

1970:  
US  
National  
Environmental Policy  
Act

1975:  
US NGO  
sues  
USAID  
over  
negligent  
pesticide  
use

1976:  
USAID  
develops  
envtl.  
review  
procedure  
s for all  
activities

1980:  
22 CFR  
216  
revised  
and  
finalized

Post-  
1980:  
Integrate  
into  
contractin  
g, project  
managem  
ent.

**PEA Provides PERSUAP Template!**





**USAID**  
FROM THE AMERICAN PEOPLE

# PEA Provides PERSUAP Template!

“Pesticide Evaluation Report and Safer Use Action Plan” ...  
... also known as a PERSUAP, and has two major parts:

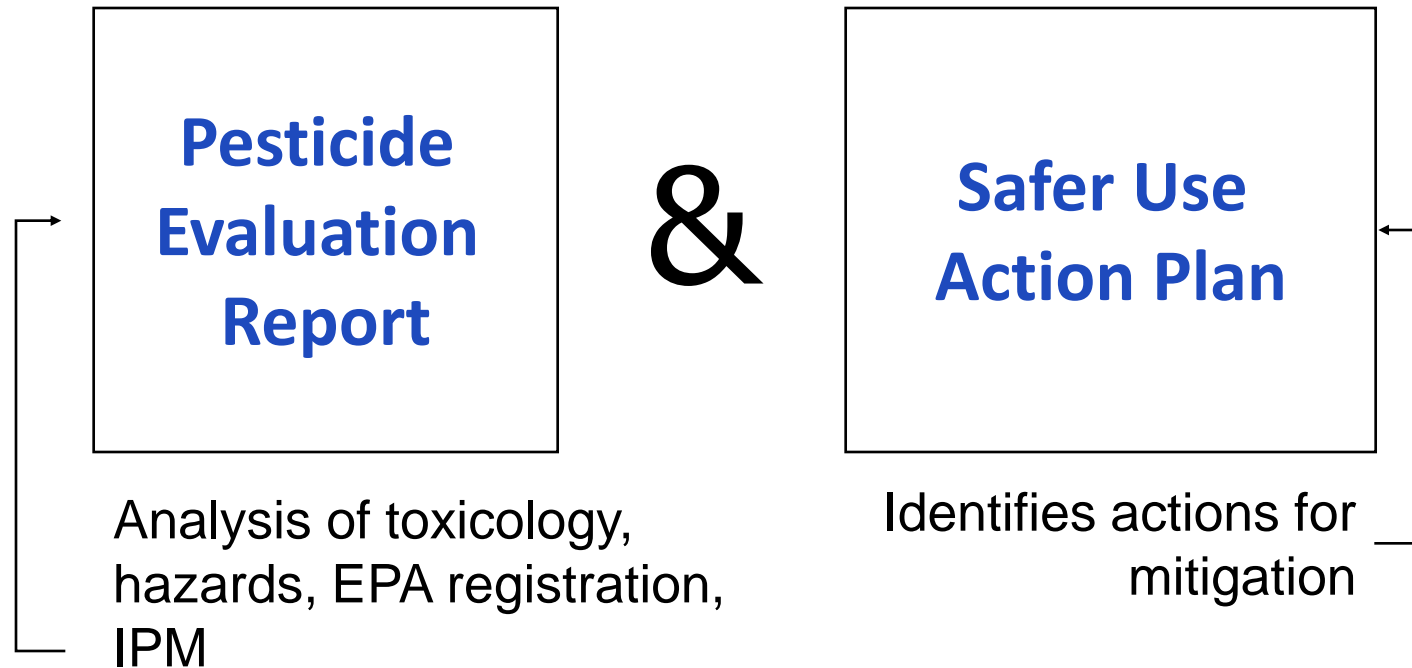

**22 CFR 216.3(b), USAID Pesticide Procedures**

# Assessing Safety– Human Health Risk Assessment (HHRA)

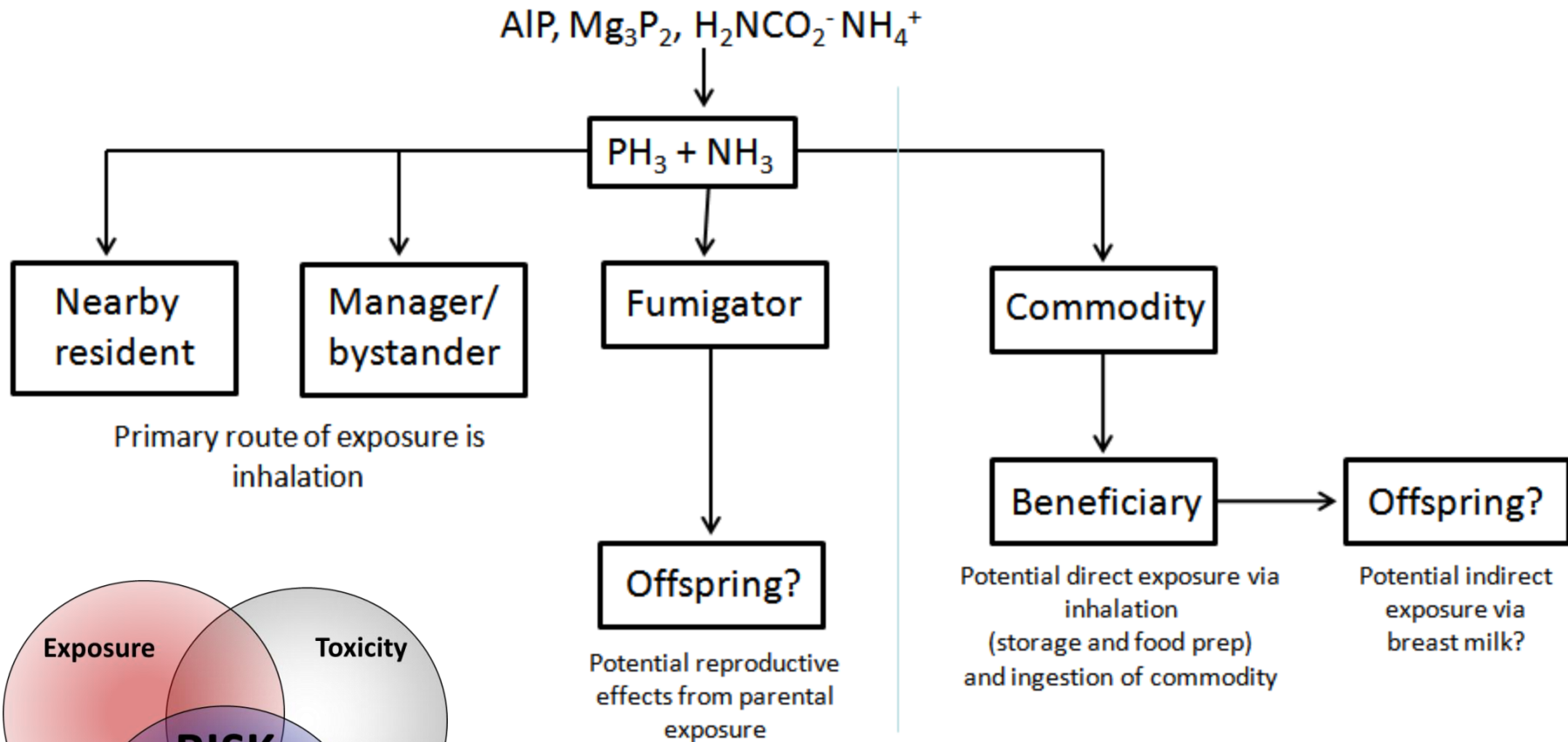

**Repeat application by fumigation providers, multiple acute exposure, chronic impacts?**

# Fumigation Management Plan (FMP)

- **Written description of the steps designed to plan for a safe, legal and effective fumigation.**
- **Contents:**
  - **Describes of the commodity and ownership**
  - **Establishes emergency plan and safety**
  - **Lists equipment and supplies**
  - **Confirms steps are met for application and monitoring**
  - **Confirms steps are met for disposal and cleanup**



USAID Food Assistance Program Name:

---

## **PHOSPHINE FUMIGATION MANAGE (SHEETED STACKS ONLY)**

**THIS FMP TEMPLATE PROVIDES A STEP BY  
ENSURE SAFE AND EFFECTIVE FUMIGATION  
FUMIGATION PERSONNEL**

### **CONTENTS**

COMMODITY AND OWNERSHIP.....	
EMERGENCY PLANNING AND SAFETY .....	
EQUIPMENT AND SUPPLIES.....	
APPLICATION AND MONITORING.....	
DISPOSAL AND CLEANUP .....	
ANNEXED LOGS AND DOCUMENTATION .....	

# What Safety Equipment Should our Fumigator be Wearing?

15-minute exposure limit of 1.0 ppm



Eye Protection

Respiratory Protection

Coveralls

Clean Dry Gloves

# What Safety Equipment do Pesticide Applicators Often (not) Wear?



**“Painters Mask” will not stop gas**



- **No inhalation mask**
- **Bare feet and hands**

# Efficacy: Pesticide Resistance

## Unknown Gas Concentration: Leaky (holes) or Gas Permeable Tarps (Need Impermeable)

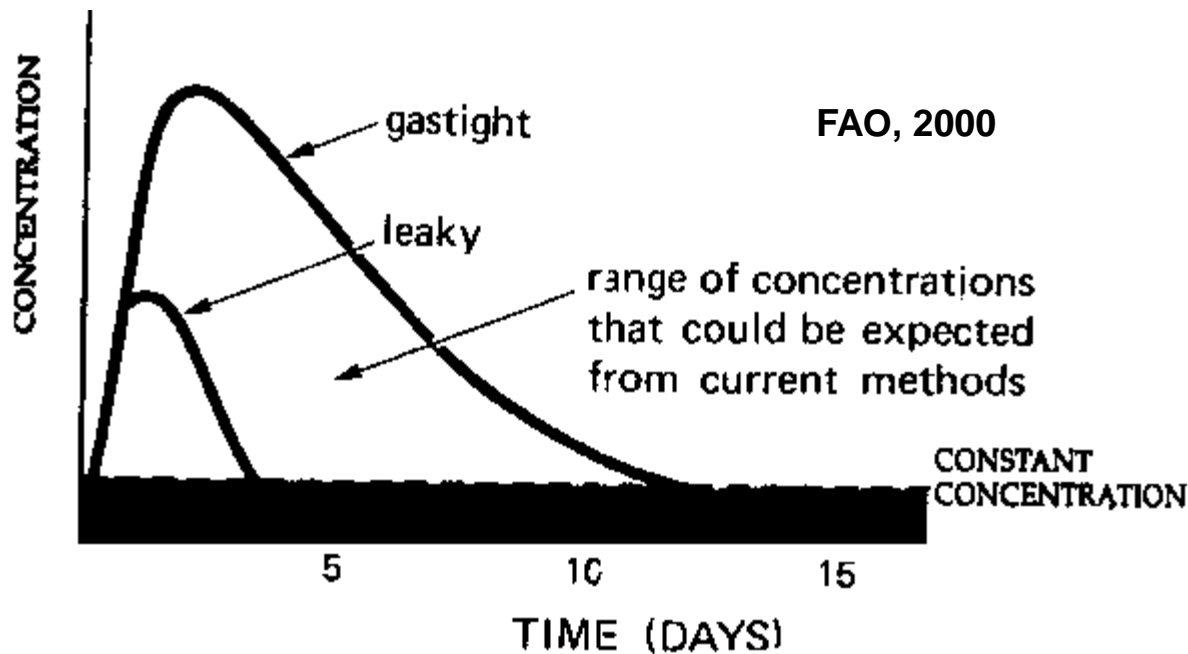

Think Gore Tex©: Liquid Impermeable, but Gas Permeable = No Good

# Post Application Gas Monitoring Devices



## Direct Read-out Meter

- Accurate from 0-200 ppm
- Alarm that goes off at 0.3 ppm

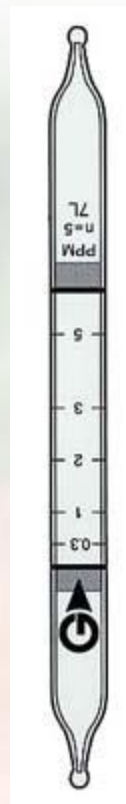

## Color-Metric Tube Detectors

- Color change over a range from 0.15-5 ppm



## Draeger Tube Detectors

- Range from 0.01-10,000 ppm

# Safety & Efficacy Needed

## New Technology Practices:

1. Appropriate PPE use and maintenance
2. Fumigation gas monitoring, efficacy and hazard
3. Gas impermeable tarps, sand snakes



Full-face respirator

Fumigation sheet covering the whole stack

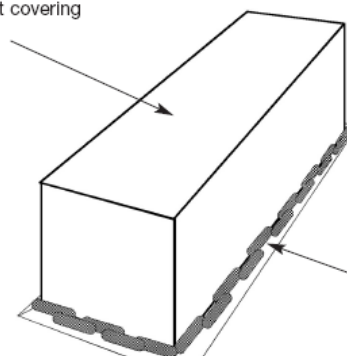

Sand snakes holding the sheet to the ground and overlapping by at least 0.3m







**USAID**  
FROM THE AMERICAN PEOPLE



## Impacts of Fumigation Assessment?

- Protect food aid resources and doing no harm
- Ability for USAID to speak authoritatively with scientific-evidence basis to justify
- New technologies into program warehouse operators and fumigation service providers
- Agency resource for food security programs, BFS
- Improve country warehousing, global market standards





**USAID**  
FROM THE AMERICAN PEOPLE

## USAID Programmatic Environmental Assessment for Commodity Fumigation at:

- <http://www.usaidgems.org/fumigationpea.htm>

### Erika Clesceri

DCHA Bureau  
Environmental Officer (BEO)

eclesceri@usaid.gov

### Emily Kunen

DCHA Environmental  
Advisor

ekunen@usaid.gov



# Plenary Q&A



**Q: Why should we change how we have been fumigating for years?**

**Q. Will existing USAID programs need to develop a fumigation PERSUAP right away?**

**Q. Will we really have to do the FMP? Why isn't the PERSUAP enough?**

**Q: Are efficacy and hazard monitoring, gas impermeable tarps and use of canister respirators apparatus firm requirements?**

**Q. What if the Fumigation Service Provider and warehouse operator does not already own and use this required equipment?**

**Q. What if monitoring equipment and breathing apparatus are not available in-country?**

**Q. Are these requirements permanent?**



**USAID**  
FROM THE AMERICAN PEOPLE

## Break-Out Exercise:



- 1. What are the steps that your organizations will take to implement the findings of the Fumigation PEA?**



Fumigation sheet covering the whole stack

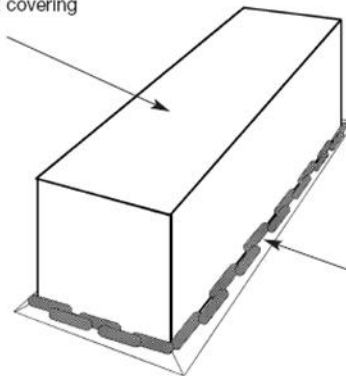

Sand snakes holding the sheet to the ground and overlapping by at least 0.3m

